

MODEL: WB-CD-1-3-SSRCT



Condiment Dispensers are designed to ensure product integrity, freshness, and sanitation, playing a pivotal role in cost management through waste reduction and eco-friendly solutions. Our Countertop Condiment Dispenser is manual: it does not require electric or pressurized gas source. Product is held under the counter, away from customer view. Ideal for dispensing standard condiments like ketchup, mustard, and mayonnaise, as well as a variety of sauces and dressings, our Condiment Dispensers have a compact footprint that streamlines your countertop space while enhancing aesthetics.

AIA FILE NUMBER:

PRODUCT OPTIONS AND ACCESSORIES

- Optional Accessories:
- Sanitizing System: includes tank, dip tube, 3ft hose
- Stainless Steel Slides for Bag Holder Base

Included Accessories:

- Ketchup Labels: other labels can be created
- 5.74in L x 3.38in W Drip Tray
- Condiment Bag Holder
- Bag Holder Base

PRODUCT FEATURES

- No electricity or pressurized gas source required
- Durable stainless steel construction
- Reduce wasted and lost product from over-serving individual packets
- Conserve time and labor while filling to-go containers
- Clean-in-Place: no dismantling required
- Easy removal and attachment of refill product
- Vol-Paks are sealed to ensure freshness and extend shelf-life
- Enhance countertop aesthetics by streamlining the small footprint

ITEM NUMBER:

MODEL: WB-CD-1-3-SSRCT

WEIGHTS & DIMENSIONS

Width	12.375 in
Depth	6.25 in
Height	16.58 in
Weight	10 lb

SHIPPING DETAILS

Ship Width	14 in
Ship Depth	14 in
Ship Height	18 in
Ship Weight	11 lb
Ship Cubic Size	2.042 ft ³
Number of Shipment Parcels	1
Ship Method	Small Parcel (FedEx, UPS, DHL)
Shipping Origin Zip Code	95688
Freight Class Number (NMFC)	250
Quick Ship Product	No
Ship Lead Time	40

PRODUCT CERTIFICATIONS



ENERGY SPECS

Primary Energy Type	No Energy Utilities
Dedicated Circuit Required	No
Electrical Remarks	Manual Pump Dispensing- no electricity of Co2 propellant needed
Annual Energy Consumption	0

ADDITIONAL SPECIFICATIONS

Condiment Dispensing Capacity	3 gal
Condiment Types Supported	Ketchup, Mayonnaise, Mustard, Ranch
Control Type	Manual
Number of Taps	1

BIDDING SPECIFICATIONS

Bidding Specifications Not Available.

TECHNICAL DRAWING

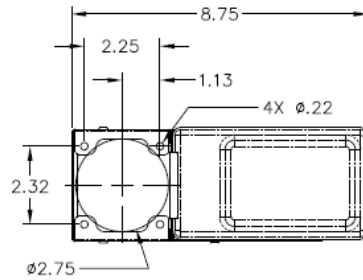
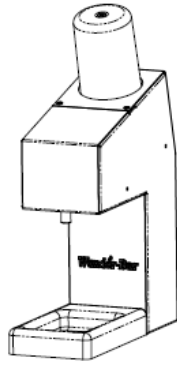

MOUNTING DETAIL:

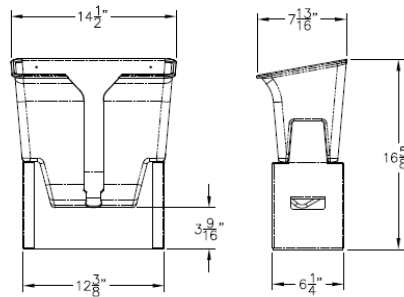
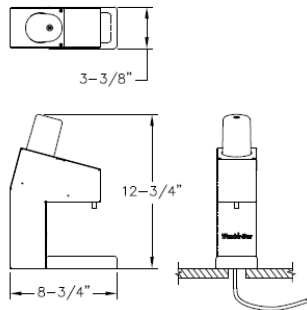

3 GALLON BAG HOLDER