



Condiment Dispensers are designed to ensure product integrity, freshness, and sanitation, playing a pivotal role in cost management through waste reduction and eco-friendly solutions. This Single Round Tower utilizes a Pressurized Gas Operated Pump Dispenser. Product is held under the counter, away from customer view. Ideal for dispensing standard condiments like ketchup, mustard, and mayonnaise, as well as a variety of sauces and dressings, our Condiment Dispensers have a compact footprint that streamlines your countertop space while enhancing aesthetics.

AIA FILE NUMBER:

PRODUCT OPTIONS AND ACCESSORIES

- Optional Accessories:
- Sanitizing System: includes tank, dip tube, 3ft hose
- Stainless Steel Slides for Bag Holder Base

Included Accessories:

- (2) Ketchup Labels: other labels can be ordered or created
- Drip Bowl Liner
- Condiment Bag Holder
- Bag Holder Base

PRODUCT FEATURES

- Durable stainless-steel construction: Tower, Faucet, and Shank
- Reduce wasted and lost product from over-serving individual packets
- Conserve time and labor while filling to-go containers
- Clean-and-Sanitize-in-Place: no dismantling required
- Easy removal and attachment of refill product
- Vol-Paks are sealed to ensure freshness and extend shelf-life
- Enhance countertop aesthetics by streamlining the small footprint

ITEM NUMBER:

MODEL: WB-RT-1-CDS-1G

WEIGHTS & DIMENSIONS

Width	17.5 in
Depth	11.5 in
Height	20.75 in
Weight	20 lb
Clearance Required: Top	3.25 in
Clearance Required: Back	0.875 in
Clearance Required: Left Side	1 in
Clearance Required: Right Side	1 in

SHIPPING DETAILS

Ship Width	14 in
Ship Depth	14 in
Ship Height	18 in
Ship Weight	20 lb
Ship Cubic Size	2.042 ft ³
Ship Method	LTL Common Carrier
Shipping Origin Zip Code	95688
Freight Class Number (NMFC)	250
Quick Ship Product	No
Ship Lead Time	40

PRODUCT CERTIFICATIONS



ENERGY SPECS

Primary Energy Type	No Energy Utilities
Dedicated Circuit Required	No
Electrical Remarks	Pressurized Gas Pump does not use electricity

ADDITIONAL SPECIFICATIONS

Condiment Dispensing Capacity	3 gal
Condiment Types Supported	Ketchup, Mayonnaise, Mustard, Ranch
Control Type	Manual
Number of Taps	1

BIDDING SPECIFICATIONS

Bidding Specifications Not Available.

TECHNICAL DRAWING

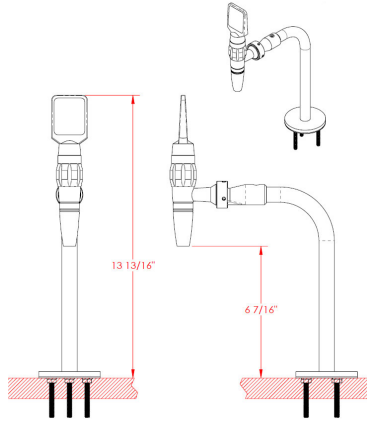

WB-RT-1 Single Round Tower

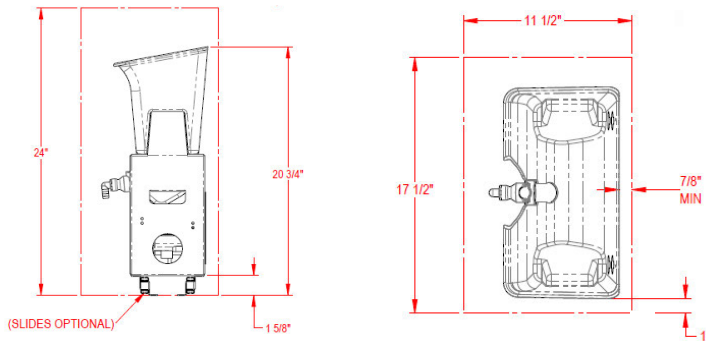
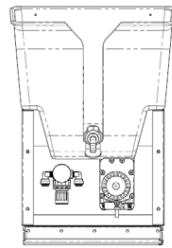

CDS-1G Gas Operated Dispensing System