

### MODEL: WB-ST-1-CDS-1G



Condiment Dispensers are designed to ensure product integrity, freshness, and sanitation, playing a pivotal role in cost management through waste reduction and eco-friendly solutions. This Single Square Tower utilizes a Pressurized Gas Operated Pump Dispenser. Product is held under the counter, away from customer view. Ideal for dispensing standard condiments like ketchup, mustard, and mayonnaise, as well as a variety of sauces and dressings, our Condiment Dispensers have a compact footprint that streamlines your countertop space while enhancing aesthetics.

AIA FILE NUMBER:

#### PRODUCT OPTIONS AND ACCESSORIES

- Optional Accessories:
- Sanitizing System: includes tank, dip tube, 3ft hose
- Stainless Steel Slides for Bag Holder Base

#### Included Accessories:

- (2) Ketchup Labels: other labels can be ordered or created
- Drip Bowl Liner
- Condiment Bag Holder
- Bag Holder Base

#### PRODUCT FEATURES

- Durable stainless-steel construction: Tower, Faucet, and Shank
- Reduce wasted and lost product from over-serving individual packets
- Conserve time and labor while filling to-go containers
- Clean-and-Sanitize-in-Place: no dismantling required
- Easy removal and attachment of refill product
- Vol-Paks are sealed to ensure freshness and extend shelf-life
- Enhance countertop aesthetics by streamlining the small footprint

ITEM NUMBER:

### MODEL: WB-ST-1-CDS-1G

#### WEIGHTS & DIMENSIONS

Width	17.5 in
Depth	11.5 in
Height	20.75 in
Weight	20 lb
Clearance Required: Top	3.25 in
Clearance Required: Back	0.875 in
Clearance Required: Left Side	1 in
Clearance Required: Right Side	1 in

#### SHIPPING DETAILS

Ship Width	14 in
Ship Depth	14 in
Ship Height	18 in
Ship Weight	20 lb
Ship Cubic Size	2.042 ft³
Number of Shipment Parcels	1
Ship Method	Small Parcel (FedEx, UPS, DHL)
Shipping Origin Zip Code	95688
Freight Class Number (NMFC)	250
Quick Ship Product	No
Ship Lead Time	40

#### PRODUCT CERTIFICATIONS



#### ENERGY SPECS

Primary Energy Type	No Energy Utilities
Dedicated Circuit Required	No
Electrical Remarks	Co2 Gas Pump does not use electricity

#### ADDITIONAL SPECIFICATIONS

Condiment Dispensing Capacity	3 gal
Condiment Types Supported	Ketchup, Mayonnaise, Mustard, Ranch
Control Type	Manual
Number of Taps	1

#### BIDDING SPECIFICATIONS

Bidding Specifications Not Available.

#### TECHNICAL DRAWING

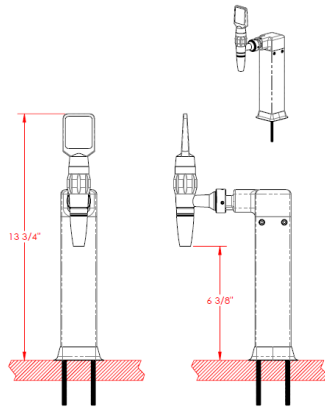

WB-ST-1 Single Square Tower

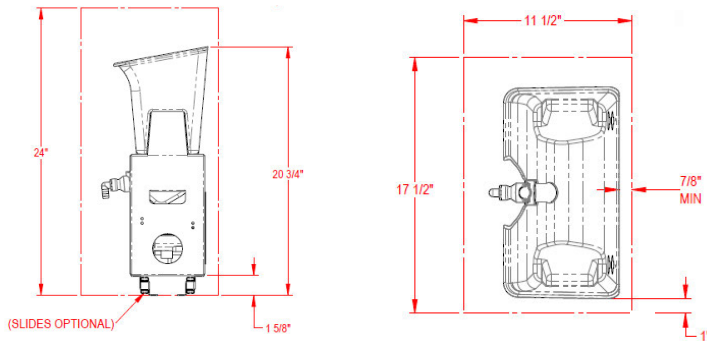
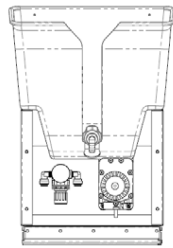

CDS-1G Gas Operated Dispensing System